

Compression rings, intermediate rings, and many oil control rings are directional, i.e. they require that a specific side faces toward the top of the piston.

The following are examples of the possible marks that could be present on one side of the ring designating the side that faces up.

- The word "Top"
- Single or double dimples
- A black dot
- An engraved ring

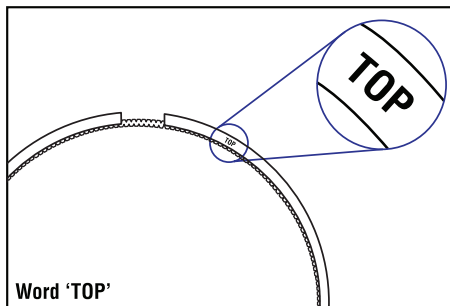

Word 'TOP'

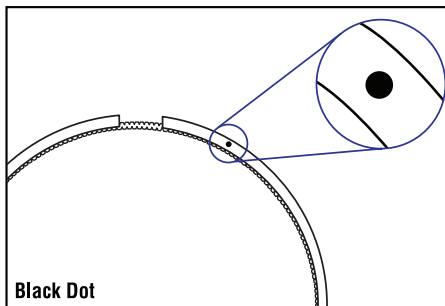

Black Dot

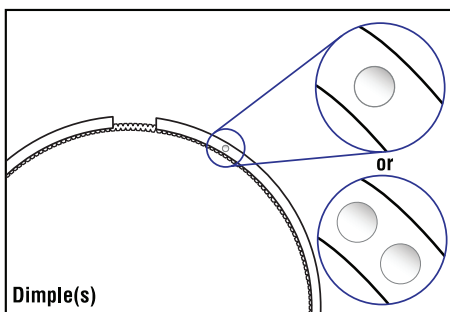

Dimple(s)

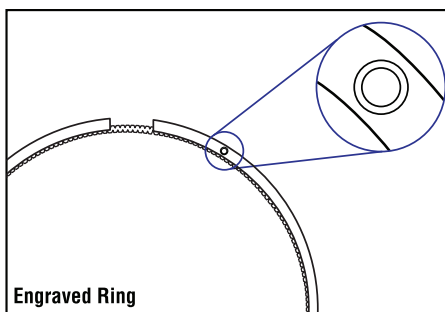

Engraved Ring

**NOTE:** There may be other marks not listed here, which are present only on one side of the ring that indicate the side that faces up



Los anillos de compresión, intermedios y muchos de control de aceite son 'direccionales', lo que significa que solamente deben ser instalados con cierto lado hacia la parte superior del pistón.

Los siguientes ejemplos muestran las marcas que pueden ser usadas en un lado del anillo, indicando que es el superior.

- La palabra TOP
- Uno o dos hoyuelos (depresiones)
- Un punto negro
- Un aro troquelado/acuñado

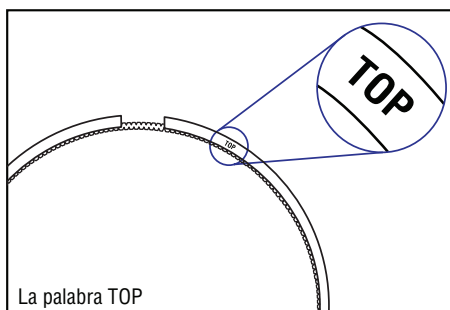

La palabra TOP

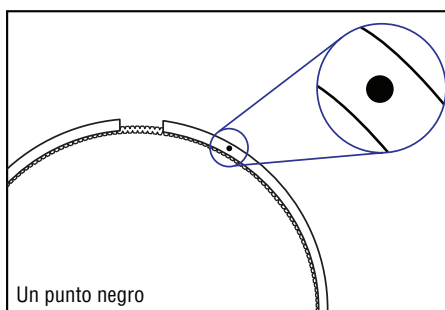

Un punto negro

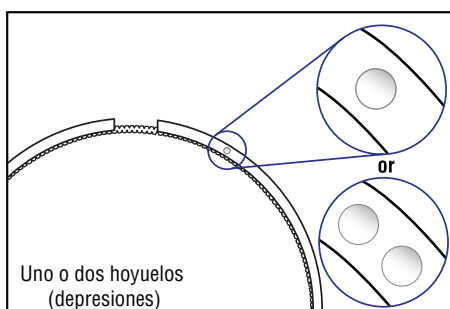

Uno o dos hoyuelos (depresiones)

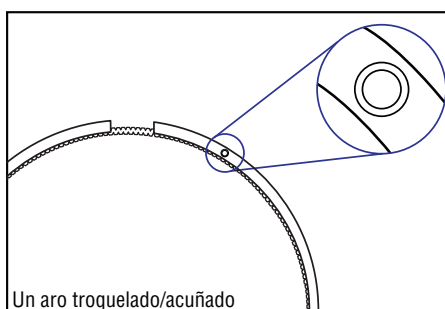

Un aro troquelado/acuñado

**Nota:** Puede haber otras marcas no mostradas aquí, que siempre estarán en el lado del anillo que va hacia arriba.

