

Compression rings, intermediate rings, and many oil control rings are directional, i.e. they require that a specific side faces toward the top of the piston.

The following are examples of the possible marks that could be present on one side of the ring designating the side that faces up.

- The word "Top"
- A black dot
- Single or double dimples
- An engraved ring

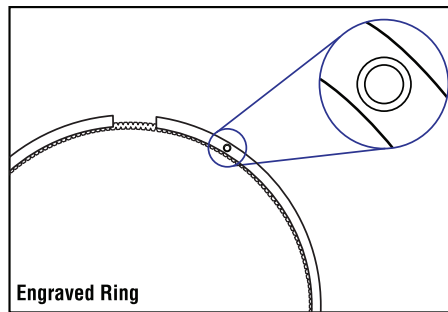
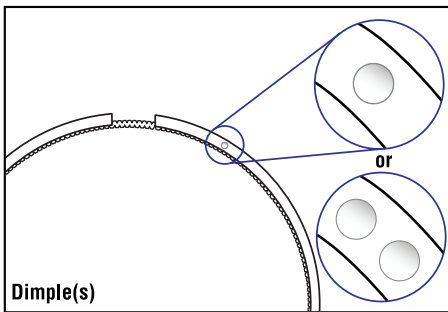
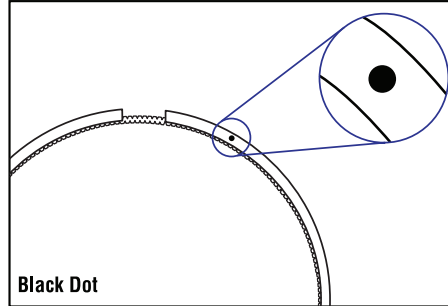
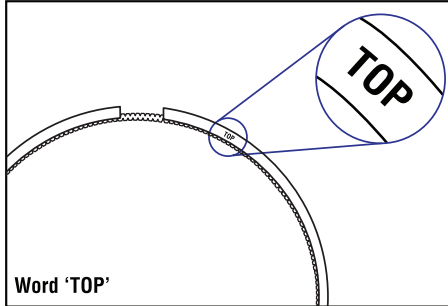

NOTE: Look for the marking that indicates the side that faces up.



Use PAI's
NOV2709
Piston
Ring
Install/Removal
Tool



Los anillos de compresión, intermedios y muchos de control de aceite son 'direccionales', lo que significa que solamente deben ser instalados con cierto lado hacia la parte superior del pistón.

Los siguientes ejemplos muestran las marcas que pueden ser usadas en un lado del anillo, indicando que es el superior.

- La palabra TOP
- Un punto negro
- Uno o dos hoyuelos (depresiones)
- Un aro troquelado/acuñado

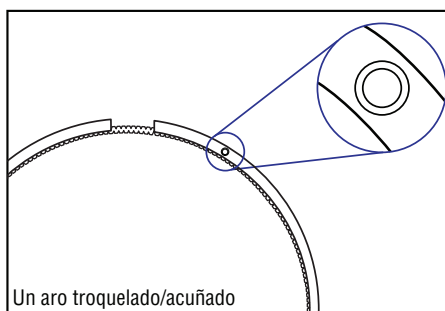
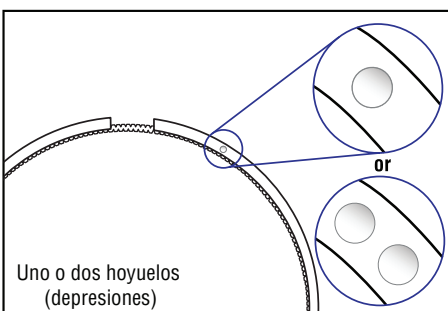
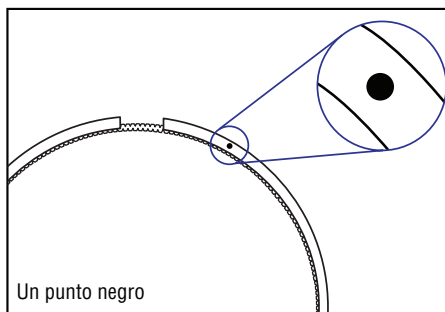
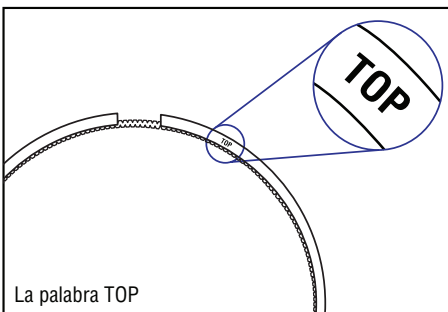

Nota: Busque la marca en cada anillo que indica qué lado debe estar hacia arriba.



Utilice la herramienta de
instalación/desinstalación
PAI NOV2709

